

ねじ軸端追加加工規格寸法
形状 C形

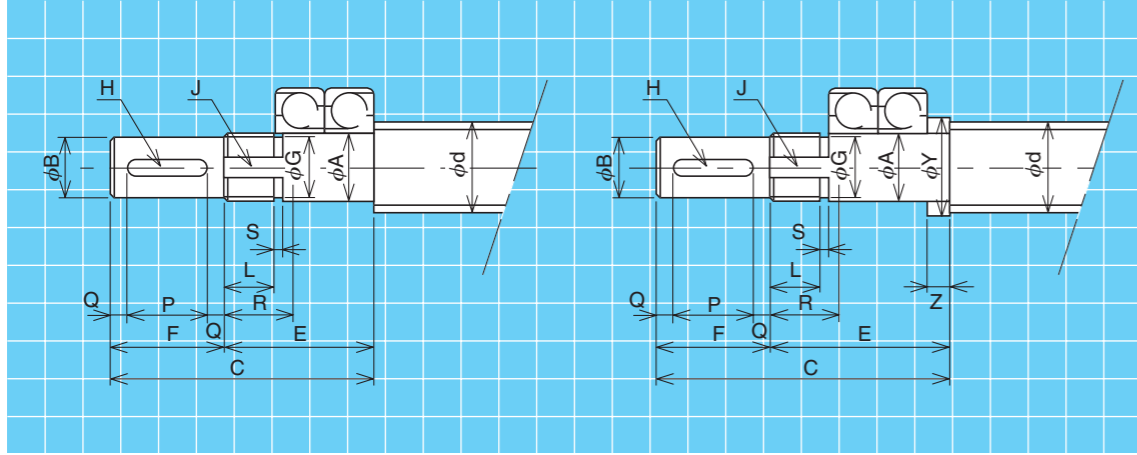

ねじ軸外径20~50

ねじ軸外径14~18

ねじ軸 外 径	軸 端 寸 法 (mm)														カラー寸法(参考)		使用 転がり軸受 例 (JISによる) 呼び番号	ねじ軸 外 径	
	Ah6	Bh7	E	F	C	ね じ 部				キ ー 溝 部					Y	Z			
						M	L	S	G	J(幅×深さ)	R	H(幅×深さ)	P	Q					
10	—	—	—	—	—	—	—	—	—	—	—	—	—	—	—	—	—	—	10
12	—	—	—	—	—	—	—	—	—	—	—	—	—	—	—	—	—	—	12
14	10	8	34	16	50	M10×0.75	9	2	8.5	3.5×1.5	13	—	—	—	15	7	7200	14	
16	12	10	37	20	57	M12×1	9	2	10.5	3.5×1.5	13	3×1.8	14	3	17	8	7201	16	
18	12	10	37	20	57	M12×1	9	2	10.5	3.5×1.5	13	3×1.8	14	3	19	8	7201	18	
20	15	12	33	25	58	M15×1	11	2	13.5	4.5×1.5	16	4×2.5	17	4	—	—	7202	20	
22	15	12	33	25	58	M15×1	11	2	13.5	4.5×1.5	16	4×2.5	17	4	—	—	7202	22	
25	17	14	35	25	60	M17×1	11	2	15.5	4.5×1.5	16	5×3	17	4	—	—	7203	25	
28	20	16	41	28	69	M20×1	13	2	18.5	4.5×1.5	18	5×3	20	4	—	—	7204	28	
32	25	20	48	36	84	M25×1.5	18	3	23	5.5×2.0	24	6×3.5	28	4	—	—	7205	32	
36	25	20	48	36	84	M25×1.5	18	3	23	5.5×2.0	24	6×3.5	28	4	—	—	7205	36	
40	30	25	50	42	92	M30×1.5	18	3	28	5.5×2.5	24	8×4	32	5	—	—	7206	40	
45	35	30	63	58	121	M35×1.5	21	3	33	6.5×2.5	28	8×4	48	5	—	—	7307	45	
50	35	30	63	58	121	M35×1.5	21	3	33	6.5×2.5	28	8×4	48	5	—	—	7307	50	