

ねじ軸端追加加工規格寸法
形状 B形

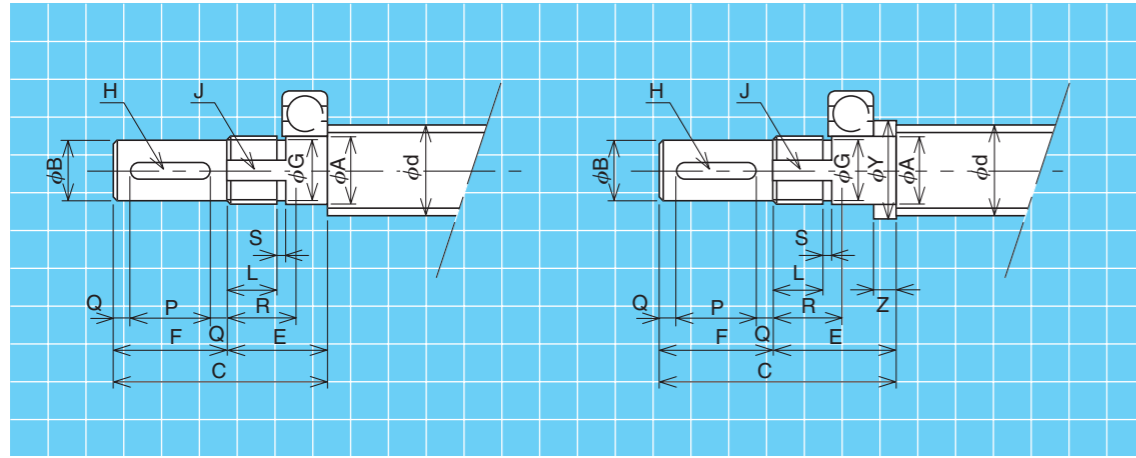

ねじ軸外径20~50

ねじ軸外径14~18

ねじ軸 外 径	軸 端 寸 法 (mm)													カラー寸法(参考)		使用 転がり軸受 例 (JISによる) 呼び番号	ねじ軸 外 径	
	Ah6	Bh7	E	F	C	ね じ 部				キ ー 溝 部					Y			Z
						M	L	S	G	J(幅×深さ)	R	H(幅×深さ)	P	Q				
10	—	—	—	—	—	—	—	—	—	—	—	—	—	—	—	—	—	10
12	—	—	—	—	—	—	—	—	—	—	—	—	—	—	—	—	—	12
14	10	8	25	16	41	M10×0.75	9	2	8.5	3.5×1.5	13	—	—	—	15	7	6200	14
16	12	10	27	20	47	M12×1	9	2	10.5	3.5×1.5	13	3×1.8	14	3	17	8	6201	16
18	12	10	27	20	47	M12×1	9	2	10.5	3.5×1.5	13	3×1.8	14	3	19	8	6201	18
20	15	12	22	25	47	M15×1	11	2	13.5	4.5×1.5	16	4×2.5	17	4	—	—	6202	20
22	15	12	22	25	47	M15×1	11	2	13.5	4.5×1.5	16	4×2.5	17	4	—	—	6202	22
25	17	14	23	25	48	M17×1	11	2	15.5	4.5×1.5	16	5×3	17	4	—	—	6203	25
28	20	16	27	28	55	M20×1	13	2	18.5	4.5×1.5	18	5×3	20	4	—	—	6204	28
32	25	20	33	36	69	M25×1.5	18	3	23	5.5×2.0	24	6×3.5	28	4	—	—	6205	32
36	25	20	33	36	69	M25×1.5	18	3	23	5.5×2.0	24	6×3.5	28	4	—	—	6205	36
40	30	25	34	42	76	M30×1.5	18	3	28	5.5×2.5	24	8×4	32	5	—	—	6206	40
45	35	30	42	58	100	M35×1.5	21	3	33	6.5×2.5	28	8×4	48	5	—	—	6307	45
50	35	30	42	58	100	M35×1.5	21	3	33	6.5×2.5	28	8×4	48	5	—	—	6307	50

B形